

Mounting Instructions

LANCOM AirLancer ON-QT60 / ON-QT90

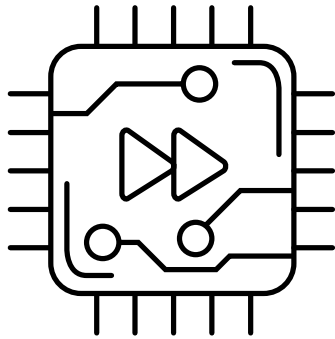

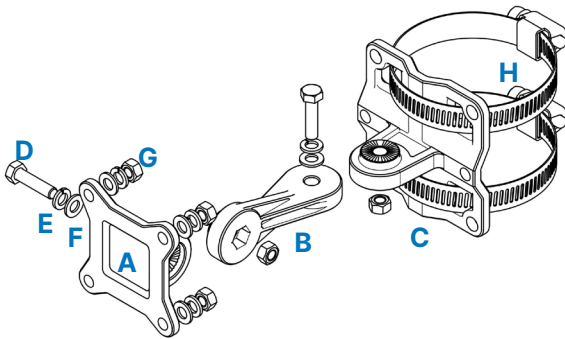

Mounting kit contents

- 1 Connection flange (A)
- 1 Connection arm (B)
- 1 Pole flange / wall bracket (C)
- 2 Hexagon head screws M5×25 (D)
- 6 Spring washers M5 (E)
- 6 Washers M5 (F)
- 6 Nuts M5 (G)
- 2 Band clamps 2,5" (H)

Mounting the antenna flange

Screw the connection flange (A) to the back of the antenna housing using the enclosed washers (F), lock washers (E) and nuts (G). Make sure that the spring washers (E) are located directly under the nuts.

Then fasten the connecting arm (B) hand-tight to the connecting flange using a screw (D), a spring washer (E), a washer (F), and a nut (G). Make sure that the spring washer (E) is located directly under the screw head.

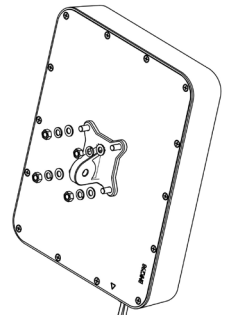

Preparation for wall mounting

If you want to mount the antenna on a wall, use the wall mount (C) as a drilling template to mark the drill holes for wall mounting.

Drill the corresponding holes at the markings and insert dowels (not included) into them if necessary. Depending on the wall material and condition, the depth and diameter of the holes must be adjusted.

Wall mounting of the antenna

Align the wall bracket with the drill holes and fasten it with suitable screws.

Now fasten the connecting arm **(B)**, which is already mounted on the antenna, to the connecting flange hand-tight using a screw **(D)**, a spring washer **(E)**, a washer **(F)**, and a nut **(G)**.

Make sure that the spring washer **(E)** is directly under the screw head and that the cables of the antenna point downwards.

Align the antenna according to your wishes and then tighten the screws of the connection arm with suitable torque.

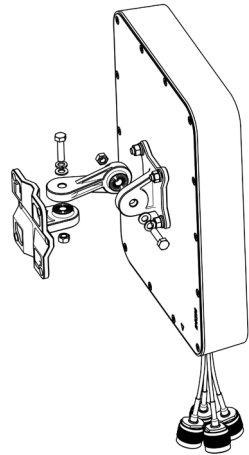

Pole mounting of the antenna

Position the pole flange **(C)** at the desired height on a suitable pole with sufficient load-bearing capacity and a diameter between 40 and 64 mm.

Then, as shown in the overview, guide the two band clamps **(H)** through the pole flange **(C)** and around the pole and tighten them after aligning the pole flange.

Then connect the pole flange **(C)** hand-tight to the connecting arm **(B)** mounted on the antenna by means of an enclosed screw **(D)**, a washer **(F)**, a spring washer **(E)**, and a nut **(G)**.

Make sure that the spring washer **(E)** is located directly under the screw head.

Align the antenna according to your requirements and then tighten the screws of the connection arm with suitable torque.

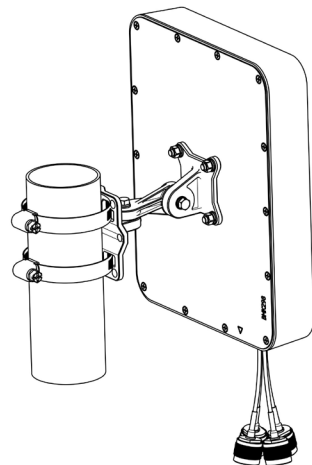

Important information

Responsible handling of high frequency

In order to comply with the protection requirements of EU Directive 2014/53 and EN 62479 with regard to the basic restrictions for the safety of persons in electromagnetic fields and the „FCC Policy on Human Exposure to Radiofrequency Electromagnetic Fields“, it is necessary to configure the correct antenna gain in the WLAN router or WLAN access point.

Electrical and Electronic Equipment Act

Please do not dispose of electrical and electronic waste in household waste, where it cannot be recycled. Make sure that your electrical and electronic waste is disposed of in accordance with the currently valid guidelines of your country.

Correct handling of antenna cables

Antenna cables are sensitive RF cables. When laying them, it is therefore important to ensure that the cables are not kinked and are bent as little as possible, as this can result in losses in terms of antenna performance. Likewise, the antenna cables should not be wound into tight cable loops.

Antenna gain and termination of unused antenna ports on access points

Unused antenna connections on the access point must be terminated with an enclosed rod antenna. For indoor access points, the terminating resistor included with the AirLancer AN-RPSMA-NJ adapter can be used. In addition, the antenna gain must be specified in the configuration of the access point.

Technical data	ON-QT60	ON-QT90
Frequency range	2,400 - 2,500 MHz, 4,900 - 7,125 MHz	
Antenna characteristics		
Radiation patterns	Horizontally 2.4 GHz: 60° Vertically 2.4 GHz: 60° Horizontally 5 GHz: 60° Vertically 5 GHz: 60°	Horizontally 2.4 GHz: 95° Vertically 2.4 GHz: 97° Horizontally 5 GHz: 99° Vertically 5 GHz: 60°
Recommended use	Point-to-Multipoint, Sector	
VSWR	2.0:1 max.	
Gain	2.4 GHz: 7 dBi max. 5 GHz: 7 dBi max.	2.4 GHz: 6 dBi max. 5 GHz: 6 dBi max.
Mechanical Data		
Dimensions (mm)	233.7 × 183.7 × 40 (W x H x D)	
Weight	900 g (Antenna without mounting kit)	
Operating temperature	-40° C to 85° C	
Color	Light grey	
Material	UV resistant plastic	
Mounting options	Wall- and pole mounting, alignable	
Cables & Connectors	4 × 100 cm ULA100 cable with N-Plug connector	
Item		
Warranty	2 years for AirLancer and accessories	
Item no.	61263	61264
Scope of delivery	Antenna, mounting kit for wall and pole mounting	